



VERTICAL ALLROUNDERS

for inserts: problem-free,
ergonomic overmoulding

ARBURG

SIMPLY PRACTICAL

**Typical vertical technology:
efficient and convenient
overmoulding of inserts.**

Clearly: much of the focus with our vertical ALLROUNDER machines is on efficiency in practice. This calls for dependable, process-reliable and precise operation. But above all, they must be one thing: ergonomic. This ensures that cooperation between human and machine is a comfortable experience. Our versatile vertical product range is fully focused on the overmoulding of inserts and offers you all the features required to help you manage your specific tasks.

WIR SIND DA.



Automated part feed system:
our rotary table machines
ensure high productivity.

Ideal for manual operations:
the low table heights of our
vertical ALLROUNDERS.

AT A GLANCE

// If you intend to use vertical injection moulding machines in your production facility, we currently offer the most comprehensive range in the entire industry. Several machine series using a variety of clamping systems, alternatively with shuttle or rotary tables, together with numerous equipment and configuration options: this gives you the flexibility to adapt machine technology to all of your production tasks. Highly efficient production at competitive unit costs. Typically ARBURG! //

Highlights

- A versatile range of products with several machine series
- Ergonomic working with a vertical free-space system
- Reproducible injection with aXw Control ScrewPilot

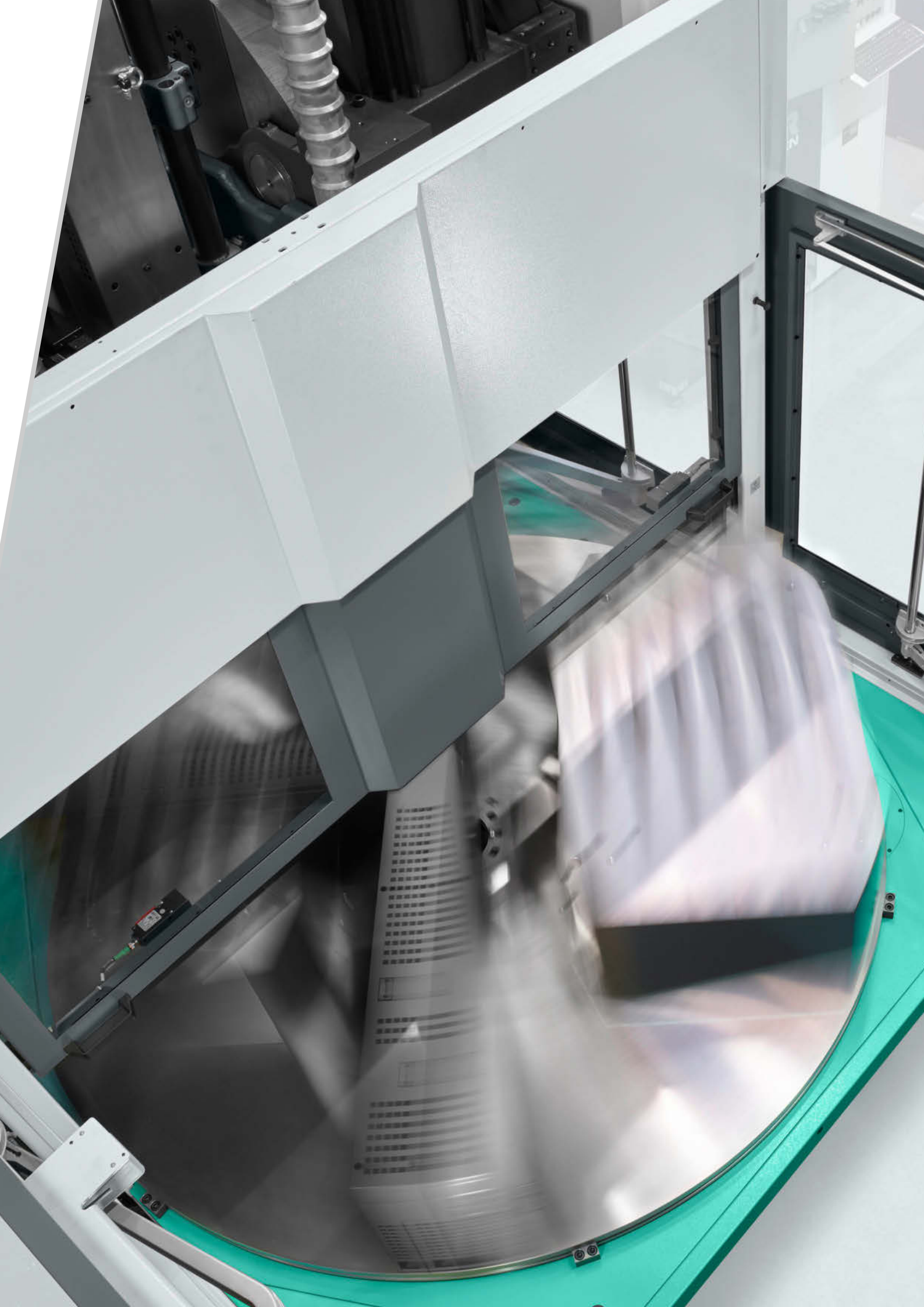

Well thought-out down to the last detail: high-quality and reliable technology forms the basis for high production efficiency.

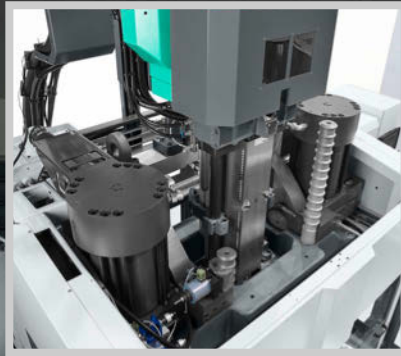

Ergonomics

Efficient overmoulding of inserts? This means organising manual work in a comfortable and time-saving manner. This is precisely the purpose of our vertical free-space system on the ALLROUNDER V: It provides unimpeded access to the mould when inserting and removing items.

Process reliability

High-quality plasticising and moulded parts: the special ScrewPilot makes reproducible injection possible in the same way as on electric machines. The servo-electric rotary tables of the ALLROUNDER V and T operate energy-efficiently, quickly and precisely.

Application suitability

The right technology for every application. We achieve this thanks to:

- a wide range of designs, machine sizes and injection units
- Vertical and horizontal arrangement of the injection units
- task-specific equipment, such as for silicone processing

Space optimisation

Especially our ALLROUNDER V machines impress with their compact design and small footprint. This makes the machines ideal for use, even in confined production environments. The scope for planning the installation of the machines remains correspondingly high.

Automation

Shorter cycle times and higher productivity: rotary and shuttle tables are available to enable simultaneous insertion and removal during the injection process. Versatile configuration options ensure that the machines can also be very easily integrated in turnkey systems.

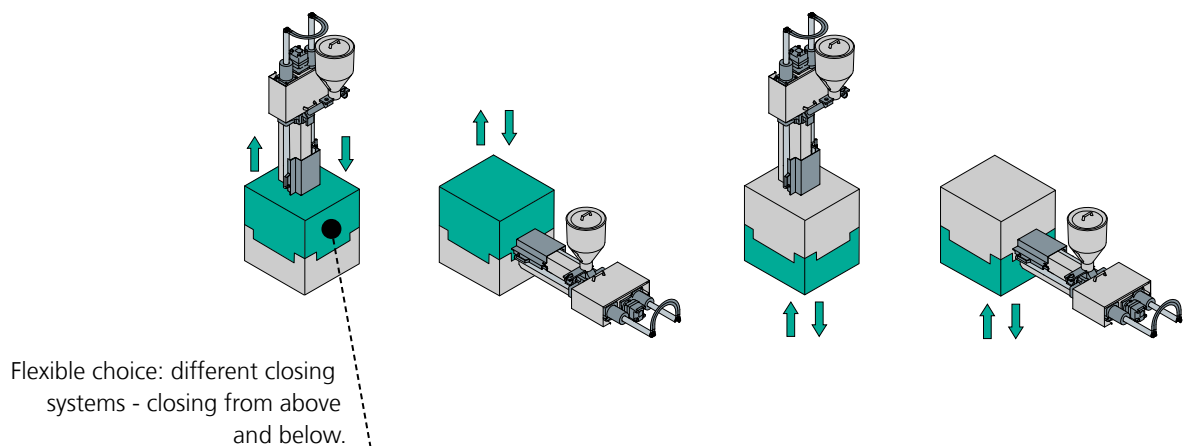

ALLROUNDER	V	T	SPECIAL
Clamping forces:	125 – 1,000 kN	1,000 – 3,200 kN	125 – 4,000 kN
Injection units:	30 - 400	70 - 2,100	30 - 2,100
Rotary table:	630 - 900 mm	1,300 - 2,000 mm	–
Shuttle table:	500 - 650 mm	–	–

Further special sizes and injection units available on request.

DRIVE TECHNOLOGY: PRACTICAL

// The hydraulic basic components make the vertical ALLROUNDERS sophisticated machines that comprehensively meet all everyday requirements. Our continuous model refinement guarantees you consistently high availability. So opting for our vertical ALLROUNDER machines gives you the certainty that proven machine components and state-of-the-art injection moulding technology have always been combined to the best possible effect. //

Adaptable: choice of technology levels and equipment for each machine type.

ALLROUNDERS	V	T	SPECIAL
T1 Single-circuit pump technology	■	–	–
T2 Two-circuit pump technology	□**	■	■
Energy-saving system (AES)	□**	□	□
Accumulator Hydraulic accumulator technology	–	□	□
Electric dosage (AED)	□	□	□
Electric rotary table	■*	■	–

💧 Hydraulic

⚡ Electric

■ Standard

□ Option

* Version with rotary table

** for ALLROUNDER 375 V only

Adapted hydraulics

The technology level of the hydraulic drive adapts perfectly to the relevant machine concept:

T1: Single-circuit pump technology for particularly energy-saving operation with serial processes.

T2: two-circuit pump technology for optimised sequences/cycles with simultaneous movements. Controlled mould locking and nozzle contact force is available in several stages. An option with a water-cooled, speed-controlled motor is available for increased energy efficiency (productivity package).

Accumulator: hydraulic accumulator technology meets the highest demands in terms of performance and process capability. Simultaneous and very precise movements are possible – all axes are regulated independently and the aXw Control ScrewPilot for reproducible injection is a standard feature.

Precision automatic control technology

The precise implementation of all movements forms the basis for high-quality parts production. The features of our hydraulic system include:

- Consumption-dependent, dynamic p/Q control
- Closed control circuit – irrespective of the degree of wear of the pump
- Fast-switching valve technology
- Valves for injection and dosing close to the consumer
- Position-related ramps enable precise positioning

Electric expansion stages

Our rotary tables are generally servo-electrically driven. As an alternative, we also offer electric dosing (AED). Both operate independently of the hydraulics and can thus be executed simultaneously with other movements. In addition to cycle-time and energy savings, their use also enhances precision.

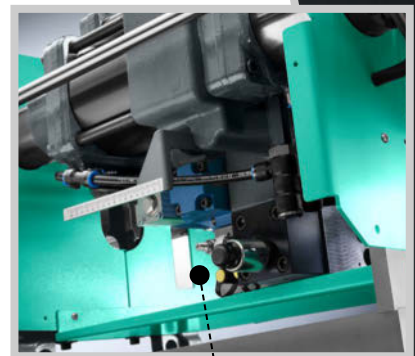

Precision: reproducible injection through valves located close to consumers.

AES or AED offers up to
20 %
ENERGY SAVING

CLAMPING UNITS: VERSATILE

// Our technology can always be precisely tailored to your production requirements! You can choose between several machine types with different clamping systems - with finely graduated sizes. The moulds can be closed both from above or below. Versions with rotary and shuttle tables enable you to work while the injection moulding process is in progress. Automated part production as well as integration of vertical ALLROUNDER machines in production lines can also be achieved without any problem. //

Vertical free-space system of the ALLROUNDER V: perfect for both manual and automated part feed systems.



Two-station shuttle table (optional): expansion for higher unit volumes.

Extend lower half of the mould (optional): easier loading of delicate inserts.

ALLROUNDER principle of the S series: swivelling clamping unit offers great flexibility.



Three-station rotary table on the ALLROUNDER T: alternative for demanding sequences.



Tie-bar-free rotary tables of the V and T series: plenty of room for moulds and media connections.

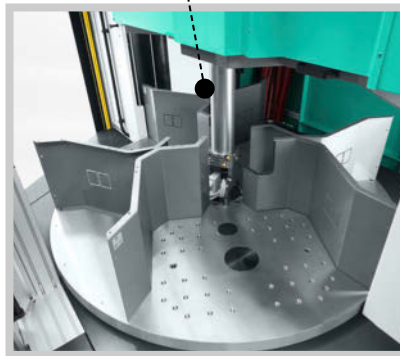

Special: special vertical machines based on proven technology.

Protective mould use

High rigidity, precision and parallelism ensure minimal mould wear: we also implement this consistently with our vertical clamping units. This is achieved through proven tie-bar guidance, pivoting C-brackets, central, torque-free application of force or sensitive mould protection devices. Our technology always guarantees you long mould service life.

Vertical free-space system

Ideal for manual activities: the mould is freely accessible from three sides on ALLROUNDER V machines. Because the fixed half of the mould is at the bottom, the set-up is also suitable for automated part feed systems, as well as the integration of shuttle or rotary tables. From machine size 275 V upwards, the clamping unit can be adjusted to different mould heights.

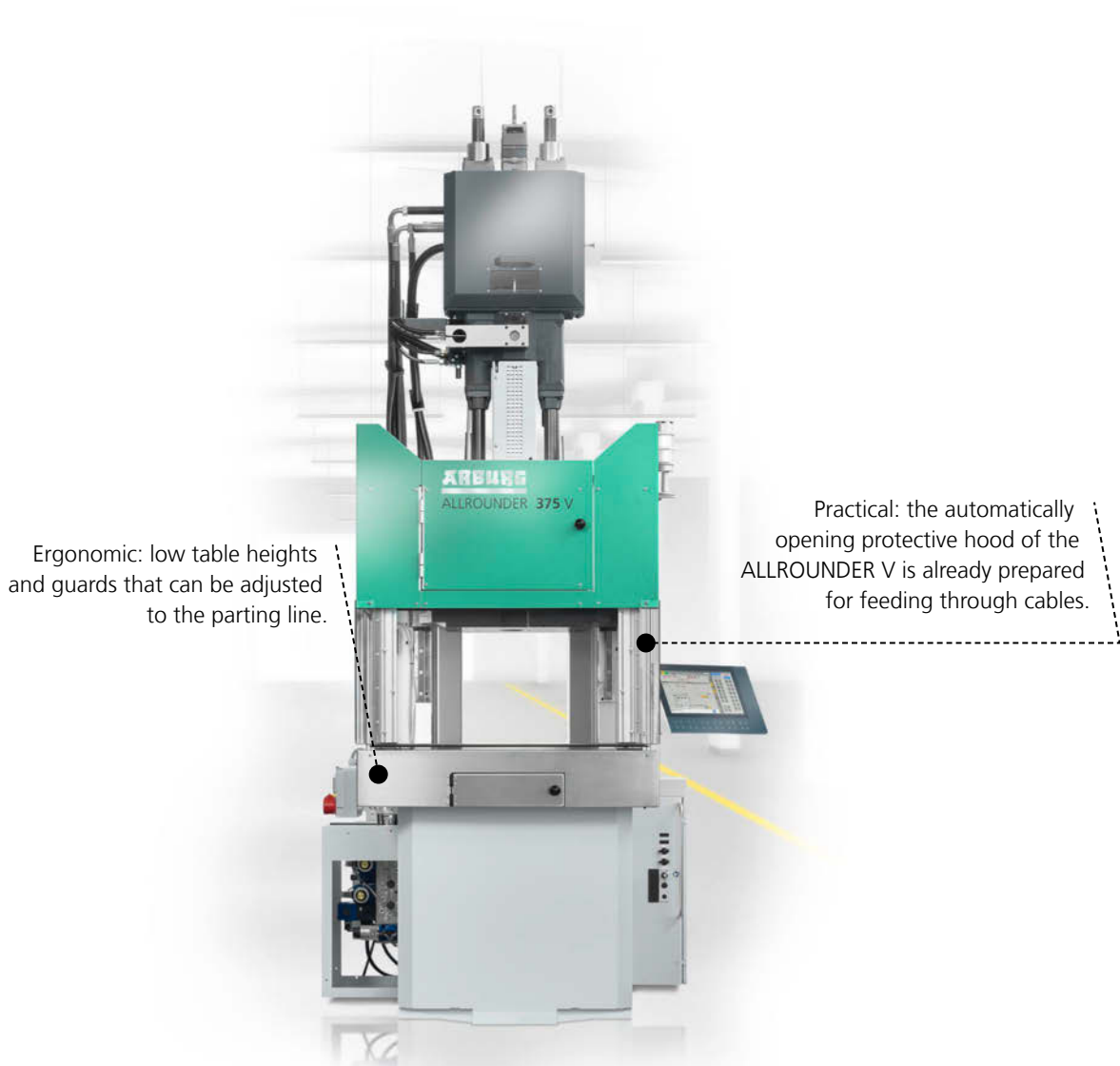

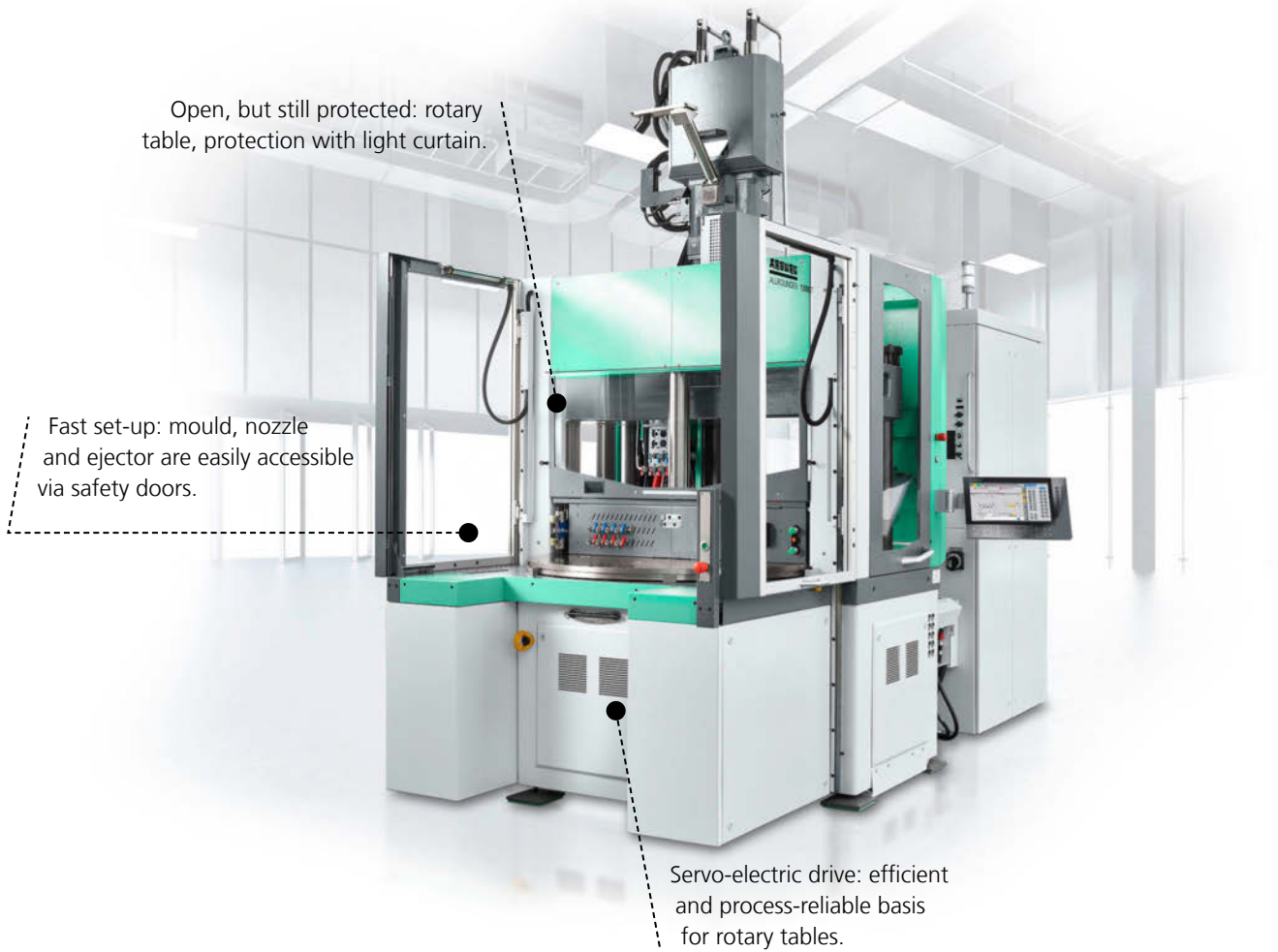

Servo-electric rotary tables

Greater productivity and automated part feed system: the two-station rotary tables of the V and T machine series enable items to be inserted and removed during the injection process. Your independent servo-electric drive is fast, precise and energy-efficient. Programmable, closed-loop-controlled speed ramps ensure smooth acceleration and braking. All of this effectively reduces cycle times.

Special clamping systems

Up to four working positions on one machine: with a swivelling lockable and interchangeable injection unit (ALLROUNDER principle), our hydraulic ALLROUNDER 170 S to 370 S machines are also suitable for overmoulding inserts. In addition, we also offer special vertical machines based on proven technology. Depending on size and type, the fixed mounting platens can be arranged at the top or bottom.

High flexibility: horizontal injection units as an alternative to vertical set-up.

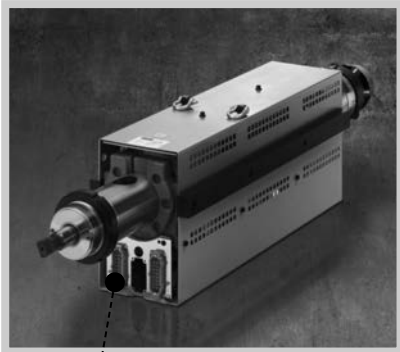

Simple changeover: central connection of all cylinder module supply units and screw quick-connect coupling.



INJECTION UNITS: ADAPTABLE

// Homogeneous material preparation and reproducible mould filling: the precise automatic control technology of our hydraulic system forms the basis for high-quality parts production. Features including the aXw Control ScrewPilot, ARBURG electro-mechanical dosage (AED) and hydraulic accumulator technology allow you to get even more out of your processes. Our injection units are quick to set up and clean. As an option, they can also inject horizontally into the parting line. It doesn't get more flexible than this! //

REPRODUCIBLE
MOULD FILLING 
with our ScrewPilot – fluctuations in the shot weight can be significantly reduced

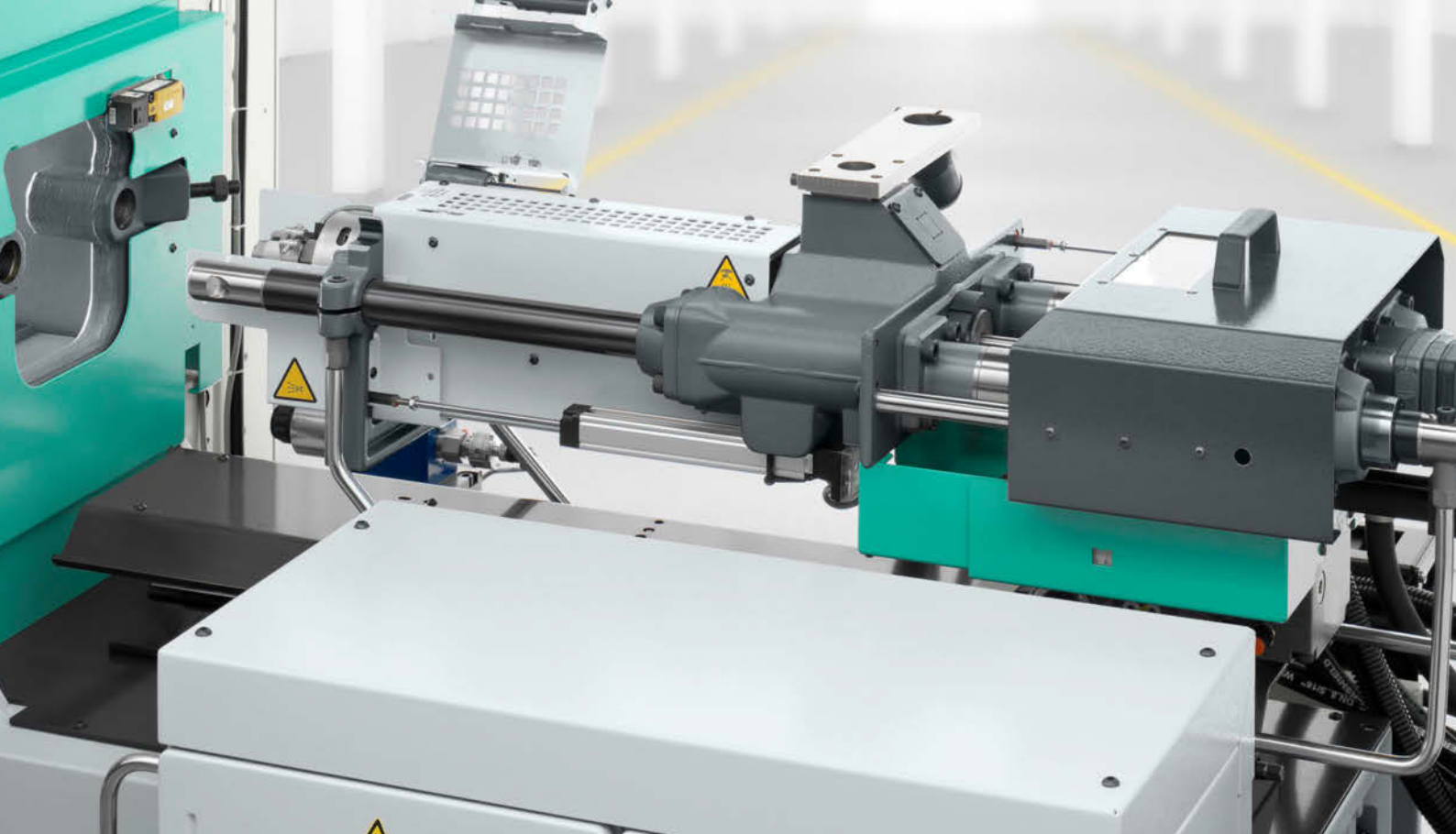

Wide variety of combinations

The cylinder modules are compatible with all series and are finely graded. A number of versions ensure optimum protection against wear. Moreover, screws with special geometries allow you to process all common plastics.

Controlled injection

Reproducible mould filling: pressure and speed are regulated during injection. Our ScrewPilot enables you to take control accuracy and moulded part quality to the next level. Hydraulic accumulator technology offers you even more dynamic injection moulding.

Torque-free nozzle contact

Our two-tie-bar guidance facilitates absolutely leak-tight nozzle contact – also ideal for both flat and extended nozzles.. The build-up of the nozzle contact forces is programmable and regulated, which reduces wear on the nozzle and mould.

AED: Electric dosing system

The AED option leads to significant energy savings with increased precision. Another result: significantly reduced cycle times in some cases. Since the melt can be dosed simultaneously and cyclically, it can also be processed more gently.



CONTROL SYSTEM: SMART

// Maintaining control over machine, mould, robotic and peripheral technology requires a suitably powerful central control system. This calls for smart technology that offers extensive data integration options, monitors and adaptively controls your processes, and actively supports you in every operating situation. All the features of our machine controllers are designed for a rapid, reliable and convenient setup and operating process. This enables you to get the best out of all your applications. //

Highlights

- SELOGICA and GESTICA – fully compatible
- Graphic sequence programming
- Direct plausibility checks
- Assistance packages and connectivity modules
- “Ready for Digitalisation”
- Central control system for complete production cells

i / Further information:
GESTICA brochure

Central management

With their unrivaled standardised operational systems, our machine controllers save time and money. The simple integration of a wide variety of peripheral equipment enables sequence management even for complete production cells, with only one data set. Short cycle times? Programmable!

Intuitive operation

The graphics-based operational philosophy can be comprehended intuitively and is always geared towards optimisation of the processes. Our unique graphical sequence programming with direct plausibility check always clearly indicates the logical position of the current programming step. Operating errors? Out of the question!

Efficient operation

Easy set-up and fast start-up. Reliable part quality and high productivity. Controlled system status and efficient support structure. Higher-level data exchange and more transparency. Our assistance packages and connectivity modules – the latter of which are a standard feature – provide the basis for all of this. Ready for digitalisation? Of course!

GESTICA builds on the comprehensive performance of SELOGICA. Gestures and more assistance make operation easier and more intuitive.



SELOGICA – the control centre with diverse functions for specialised technology, enabling even non-standard sequences to become standard in your work.

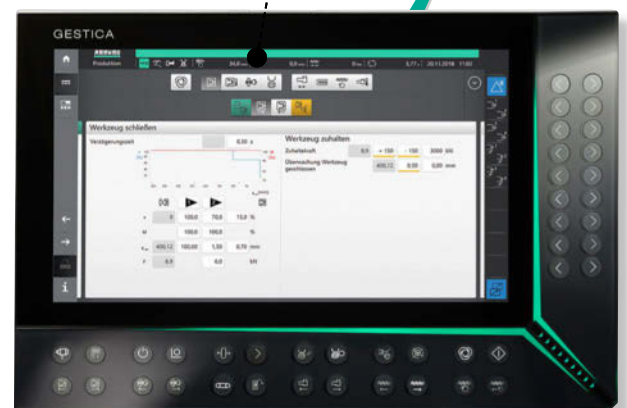

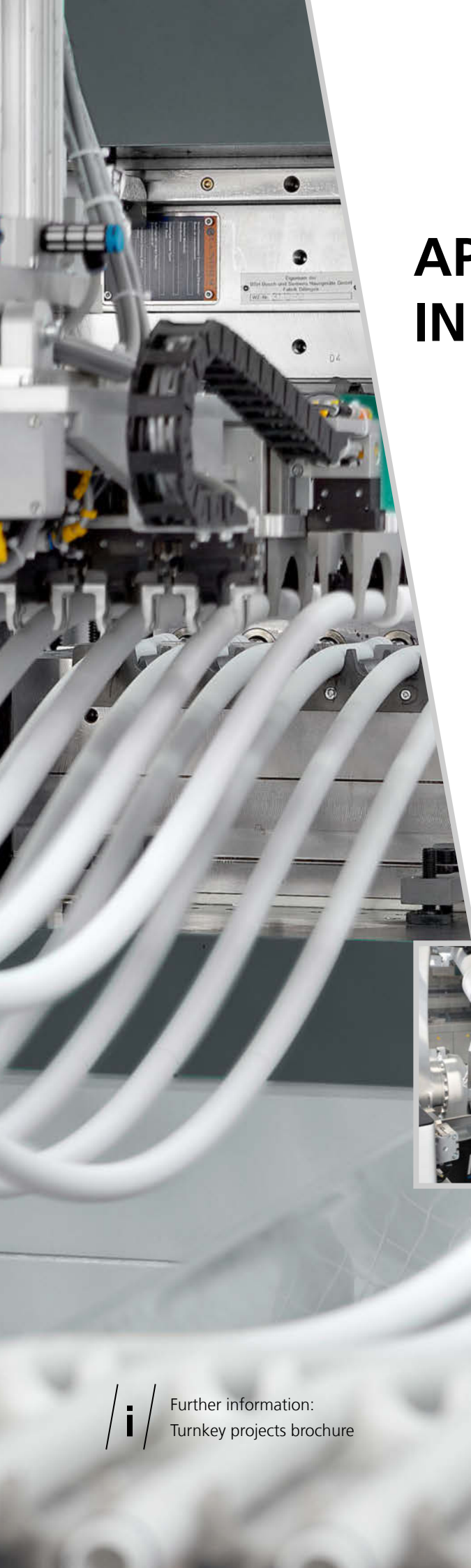

APPLICATIONS: IN PRACTICE

// The high level of ergonomic efficiency, comprehensive process security and reliability and simple integration into automated production lines all bring you decisive added value when it comes to the overmoulding of inserts. From our exemplary free-space system, shuttle or rotary table versions, through to special machines tailored directly to your production tasks: when you use our vertical ALLROUNDERS, you can process all known injectable material types efficiently and cost-effectively. //

Complex hybrid components:
complete turnkey systems from
a single source.



Automated overmoulding:
robots can also be used as a reliable
way to feed in flexible inserts.

i / Further information:
Turnkey projects brochure

Hybrid plug with silicone seal for a parking assistance feature (automotive).

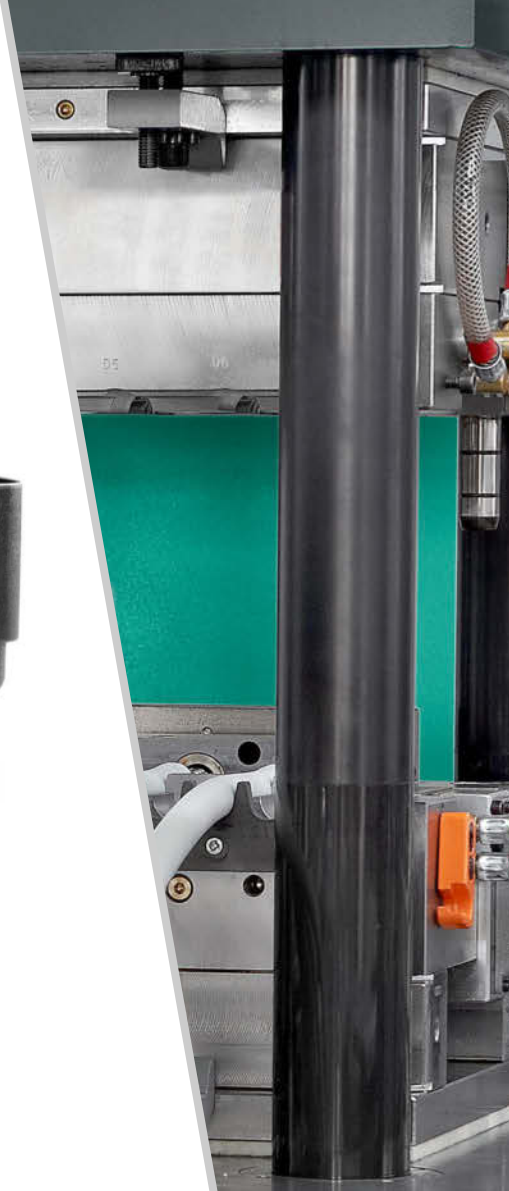

Inline production: reel-to-reel systems tailored to the application



Multi-component technology: superior flexibility thanks to versatile configuration options.



Manual insertion and removal: our vertical free-space system ensures ergonomically efficient sequences.

i / Further information:
Application expertise brochure



Scan this code to visit our
Media Centre: in-depth,
captivating, entertaining.

ARBURG GmbH + Co KG
Arthur-Hehl-Strasse
72290 Lossburg
Tel.: +49 7446 33-0
www.arburg.com
contact@arburg.com

WIR SIND DA.